

34th WEDC International Conference, Addis Ababa, Ethiopia, 2009

**WATER, SANITATION AND HYGIENE:
SUSTAINABLE DEVELOPMENT AND MULTISECTORAL APPROACHES**

**Modelling the benefits of urine diversion for resource
recovery: Case study of Arba Minch, Ethiopia**

F. Meinzinger, Germany

REFEREED PAPER 134

Urine diversion provides a possibility of linking environmental sanitation and agricultural production. In order to support decision making with regard to the implementation of dry, urine-diverting toilets (UDDT), material flow analysis (MFA) can represent a useful tool. This paper presents the use of a material flow analysis for water, sanitation and organic waste applied to the city of Arba Minch, Ethiopia. Mass flows as well as nitrogen and phosphorus flows are assessed. The results highlight the potential for reduced environmental pollution as well as the recovery of valuable nutrients through the application of urine and compost. Different implementation pathways are modelled including uncertainty analyses. The results show that the replacement of nitrogen and phosphorus fertiliser currently required within the system boundaries is possible at UDDT implementation rates between 20 and 50%. If more households are equipped with UDDTs, excess nutrients can be delivered to surrounding areas with higher farming intensities.

Introduction

Improving the sanitation situation in Ethiopia requires intensified actions conjoint with supported decision making. Particularly in urban areas, system analyses can help understanding the challenges of the current situation and analysing possible future developments. Planning can thus be supported by system analyses, particularly when it comes to alternative sanitation systems that differ from conventional sanitation solutions.

The town of Arba Minch with about 80,000 inhabitants is located in the Southern Nations, Nationalities and People's Region. The situation in Arba Minch is typical for an Ethiopian medium-sized town. The predominant toilet facilities are simple pit latrines, which are used in about 78% of the households. Those pits usually have only insufficient superstructures and are prone to collapsing and flooding (AMU & ARB, 2007). Currently, there is no centralised management of sanitation facilities in place. Households and institutions perceive the collection of sludge from pits and septic tanks as a challenge since there are no vacuum trucks for desludging available in town, but have to be ordered from far away places. From an environmental perspective the lack of legal disposal sites or treatment facilities for the pit contents presents a risk for groundwater and surface water pollution. About 10-16% of the population do not have access to any kind of sanitation system and practice open defecation (DHV Consultants, 2002; Esatu, 2008).

The municipality and other actors have realised the need for an upgrading of the town's sanitation system. This is in line with the government's Universal Access Plan to achieve access to WASH services for all by 2012. A planning process has started in Arba Minch including the assessment of different options. In addition to the assessment of economic aspects environmental objectives such as the reduction of environmental pollution and the efficient use of the resources water and nutrients should be included in the analysis. This study presents the use of a Material Flow Analysis (MFA) to assess the use of resources and the environmental impact of a sanitation scenario based on the introduction of urine-diversion toilets in Arba Minch.

Urine diversion as alternative sanitation technology

Usually, wastewater consists of a mixture of different flows (i.e. greywater from washing and cleaning, urine and faeces plus possibly flush water), which have different characteristics. The separation of these flows at the source represents an option for more specific treatment and use of the resources contained in the wastewater. So-called ecological sanitation systems are based on the philosophy that wastewater is seen as a source for nutrients for agricultural purposes or as an energy source using the high organic content in excreta. In addition, saving of water and reuse of water in a hygienic way is encouraged within the framework of ecological sanitation.

General advantages and constraints of urine diversion

The use of excreta as plant fertiliser is well known by many farmers around the world due to the high amount of plant-available nutrients in urine and faeces. Particularly urine has a high ratio of nitrogen and phosphorus, i.e. about 10 g N per person and day and 1 g P per person and day excreted in urine (Meinzinger and Oldenburg, 2008). In order to allow for a safe use of these nutrients, it is advisable to keep the fractions urine and faeces separate, since it is the faeces that contain the largest share of pathogens whereas urine can be considered to be sterile when leaving the body. An additional advantage related to the separation of urine and faeces - provided that the faeces are kept dry - is the improvement in terms of reduced smell and fly nuisance. Faeces can be easily dried using additives like ash or woodchips and can later be composted and used as soil conditioner. The World Health Organisation has realised the potential of source-separated human urine and faeces and has released guidelines on how to safely use excreta in agriculture (WHO, 2006). The amount of nutrients from one person is generally sufficient to fertilise an area of about 200 to 400m². The nutrient availability is comparable to mineral fertiliser (Kirchmann and Petterson, 1995) and, therefore, mineral fertiliser such as DAP or Urea can be replaced. This is particularly important in the light of increasing fertiliser prices as a result of rising energy prices for the production of N fertiliser and the finiteness of natural phosphate rocks. Due to the dependence on world market prices, Ethiopian farmers have seen sky-rocketing increases of inorganic fertiliser prices from \$300/ton in January 2007 to now more than \$1000/ton (Demilew, 2008). This jeopardises the use of sufficient nutrients to replenish the demand.

Some general benefits and challenges regarding the implementation of urine-diversion toilets are summarised in the following table.

Table 1. Advantages and constraints of urine diversion	
Advantages	Constraints
<ul style="list-style-type: none"> • Reduction of smell and flies in the toilet compared to pit latrines • Can be designed to be used without water • No pits needed → no digging • Ease of emptying compared to desludging of pits or septic tanks • Decreased risk of environmental pollution • Provision of urine as plant fertiliser • Provision of faeces as soil conditioner • Financial benefits through the use of these products in agriculture 	<ul style="list-style-type: none"> • Special kind of toilet slabs needed • Training and information of users required • Implementation requires high awareness of users and appropriate follow-up strategies • Risk of misuse that can result in unfavourable conditions in the toilet • Toilet design (superstructure) needs to be adapted • Transport requirements for urine • Drying additives for faeces required (e.g. ash, soil, woodchips) • Higher costs than simple pit latrines (but comparable costs to septic tank system)

Urine-diversion in Ethiopia

Several types of urine-diversion toilets using different materials are available for a wide range of costs on the international market. In Ethiopia, squatting toilets (“Turkish toilets”) as well as sitting toilets are generally used. Usually, in public toilets as well as in households that are used to simple latrines squatting is preferred, whereas an adoption of “Western” sitting type of toilets in hotels, institutions and new housing areas can be observed. Currently, different squatting types as well as a sitting types out of fibre-glass reinforced plastic is available. In addition, the cooperation with an Ethiopian ceramics factory recently brought forth the production of a squatting type of toilet out of ceramics. Photographs 1 to 3 show different urine-diverting toilet models available in Ethiopia.



**Photograph 1. Sitting toilet
(glass-fibre)**



**Photograph 2. Squatting toilet
(glass-fibre)**



**Photograph 3. Squatting
toilet (ceramic)**

There are several organisations and projects involved in piloting and up-scaling the use of urine diversion in different regions and different socio-cultural settings in Ethiopia. Main actors in this regard are SUDEA (Society for Urban Development in East Africa), CRS (Catholic Relief Service), ESE (Ecological Sanitation Ethiopia) and ROSA (Resource-Oriented Sanitation Concepts for Peri-Urban Areas in Africa). Experiences in terms of user acceptance as well as agricultural use of the products (farmers' acceptance and crop yield) have been very positive so far. For example, maize as well as other crops were fertilised with urine in trials in Arba Minch carried out by ROSA. Nevertheless, high efforts for promoting this special kind of sanitation system are usually required to advocate the shift from open defecation or simple pit latrines to urine-diverting toilets. Only when households realise the additional benefits like provision of plant nutrients, improved hygiene or better adaptability to adverse soil and groundwater conditions, they are willing to accept the unfamiliar design of the toilet seat and possible challenges such as the provision of drying additives. Socio-cultural aspects play a crucial role for the implementation of new sanitation concepts. A detailed discussion of these aspects in the case of Arba Minch is given by Esatu (2008).

Material Flow Analysis (MFA) for environmental impact modelling

Material Flow Analysis is a tool that allows the study of fluxes of resources being used and transformed as they flow through processes within specific system borders (Brunner and Rechberger, 2004). The method MFA provides a link between human activities and their impact on the environment by highlighting the interlinkages of different flows of the substances or resources under investigation. A material flow analysis generally starts with a system analysis aiming at a specific objective. This includes setting up the system boundaries and defining the flows and processes, which are expressed as variables in an equation system (i.e. the model approach). Parameters are used to set up the equation system and to determine the variables. After the data collection of parameter values, the total material flows are assessed by simulations including sensitivity and uncertainty analyses. Finally, the results are analysed and presented. An MFA model usually consists of variables such as input flows, output flows and internal flows as well as processes (stock rate changes). Other studies on material flows in urban water and wastewater systems were done, for example, by Belevi (2002), Forster et al. (2003); Montangero et al. (2004) and Thitiphon et al. (2005).

MFA system for the town of Arba Minch

The system boundary in this study is delineated to be the administrative area of the town of Arba Minch. The processes under consideration are those that are relevant for water supply, wastewater and organic waste disposal. Since the analysis of possibilities for recycling of nutrients and water was one of the objectives, also agriculture was included as one of the processes. The flows that were studied include relevant mass flows, water flows, total nitrogen flows and total phosphorus flows. Figure 1 illustrates the processes (i.e. the boxes) and flows of the current water and sanitation system in Arba Minch. After an initial assessment of the system the two processes "Institutions" and "Industry" were not considered in the further analysis since their flows contributed less than 1% to the total system throughput. According to Brunner and Rechberger (2004) such material flows can be neglected.

The calculations were done using the material flow modelling software SIMBOX developed by EAWAG (Baccini and Bader, 1996). In order to be able to model the different input, output and internal flows as well as stock rate changes, a set of parameters was established for which data was collected. In total, the MFA model was based on 67 parameters. These parameters were derived by various sources. An extensive baseline study on the current sanitation situation in Arba Minch was carried out using key informant

interviews, focus group discussions, transect walks and household questionnaires (AMU and ARB, 2007). The main actors in this regard were the Arba Minch Town Water Service and Arba Minch University. In addition to these activities literature was used to determine parameter values.

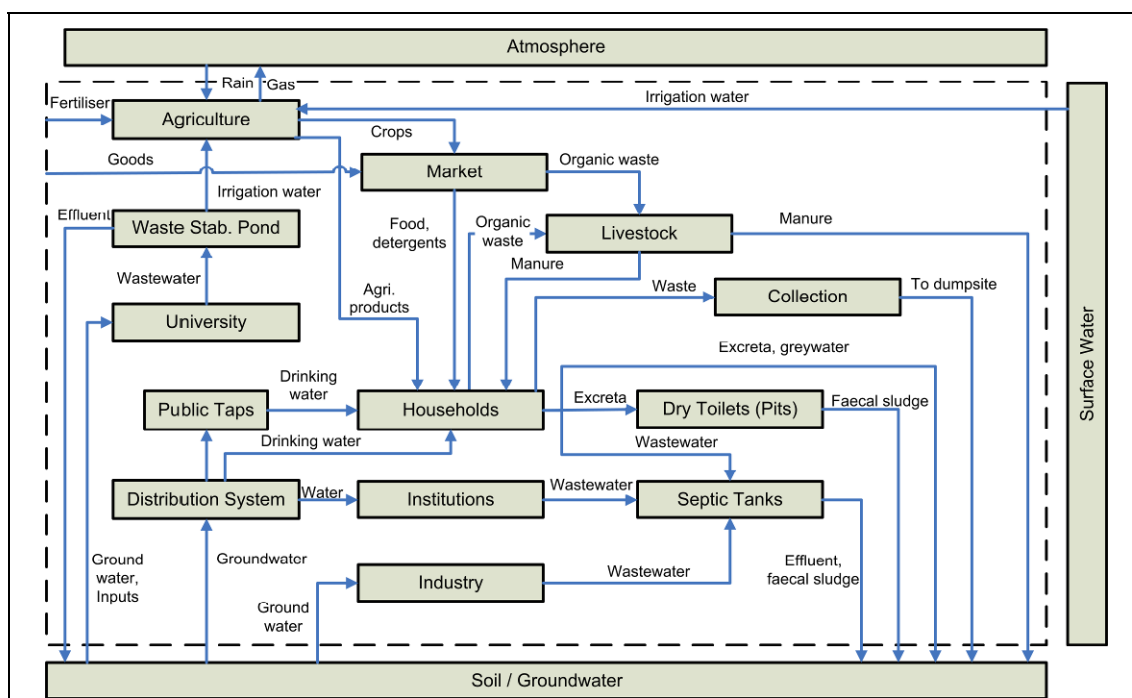

Figure 1. Flow scheme of the MFA model for Arba Minch (current situation)

A stationary model was developed. The calculations were carried out including an uncertainty analysis based on the Gaussian law of error propagation. Therefore, for each parameter value ranges were used in addition to average values in order to assess the uncertainty of the results. Wherever no uncertainties could be defined for a particular parameter, a general uncertainty of 10% was assumed.

After the initial analysis of the current situation a scenario was set up based on the introduction of urine diversion toilets. Following flows were introduced:

- Separated urine from urine diversion toilets as fertiliser to agriculture
- Faeces, organic waste and faecal sludge from pit latrines and septic tanks to co-composting plant
- Compost to agriculture.

Description	Unit	Current situation	Option 1: UDDT new access	Option 2: UDDT pit replacement	Option 3: UDDT for all
Households with UDDT (urine to agriculture, faeces to co-composting)	%	0	16	78	100
Households practising open defecation	%	16	0	16	0
Households/institutions with septic tanks	%	6	6	6	0
Organic waste from households added to co-composting	%	0	16	78	100

For the analysis of the urine-diversion scenario several parameters were introduced, which allowed a modelling of different development pathways, in the following called options. In option 1 only those

households who currently don't have access to any kind of sanitation are equipped with urine-diversion, dry toilets (UDDT). Option 2 considers the replacement of all conventional pit latrines by UDDT. Option 3 assesses the implementation of UDDT in all households. The respective parameters are shown in Table 1.

Results of the analysis

Current situation

The analysis of the current situation showed that nutrients from organic waste as well as human excreta are not used in a productive manner but are mostly discharged into the environment, particularly on soil, thus leading to potential groundwater pollution. Annually, more than 280 tons of nitrogen and 54 tons of phosphorus are discharged onto soil of which more than 80% are from open defecation and pit latrines. Nutrient input to the households is mainly from goods from outside Arba Minch, since there is only little urban agriculture in the town. The main agricultural producer in the town is a state farm, which currently uses only nitrogen fertiliser in the form of Urea since the soil phosphorus content is relatively high¹. Yet, there is the potential of overexploitation of natural phosphorus sources if no phosphorus fertiliser is applied. For the model approach an average application of one quintal Urea per hectare and one quintal DAP per hectare was assumed, which is common in South Ethiopia. This was done to show the potential of nutrient recovery for both, nitrogen and phosphorus. The current theoretical fertiliser demand equals 40.4 ± 6.2 tons nitrogen per year and 14.6 ± 1.3 tons phosphorus per year.

The only current form of recovery of nutrients is the feeding of livestock on organic waste. Based on estimations of the livestock number in Arba Minch and the percentage of organic waste taken up by livestock, the nutrient inputs to livestock amount to about 49 tons nitrogen per year and 8 tons phosphorus per year. Yet, livestock manure is used only occasionally as fertiliser, but rather for energetic purposes or totally discarded from the recovery loop. Figure 2 illustrates the total nitrogen flow within the system boundaries for the current situation. Average values as well as uncertainties are given.

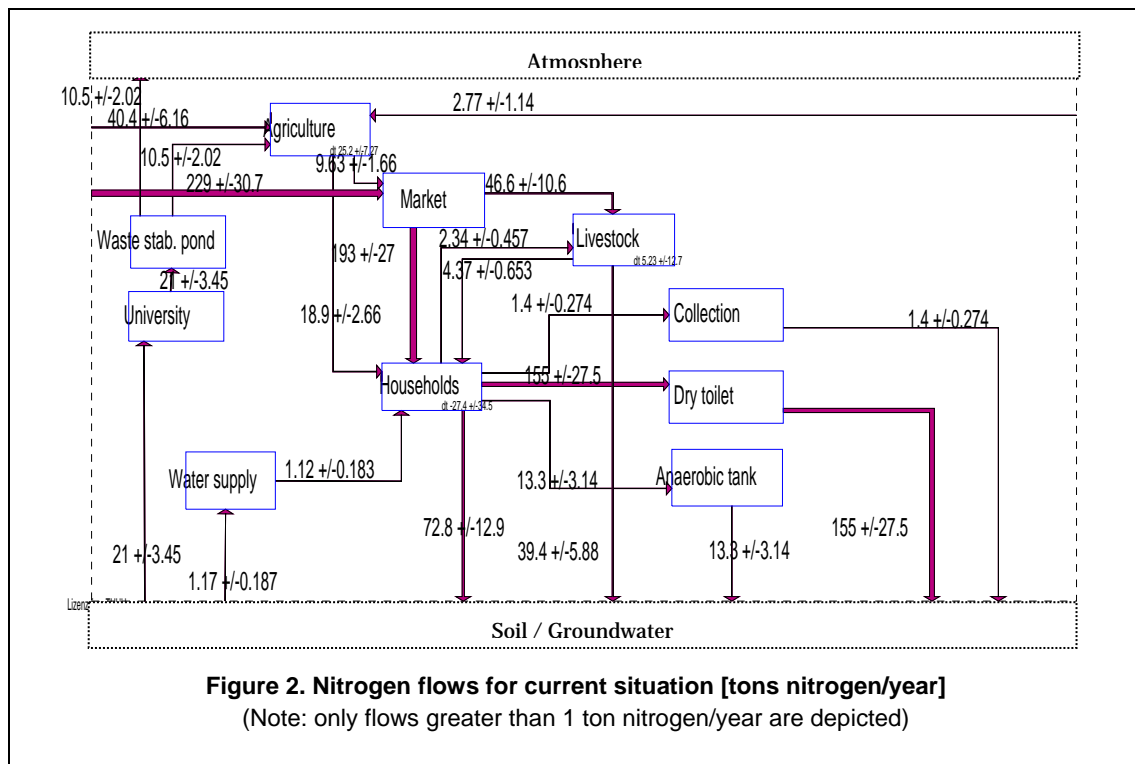

Overall, more than 120 tons N/y could be exported. Emissions to soil and groundwater are reduced by more than 70% to about 80 tons N/y. This remaining nitrogen load is mainly derived from greywater discharged into the environment and animal manure.

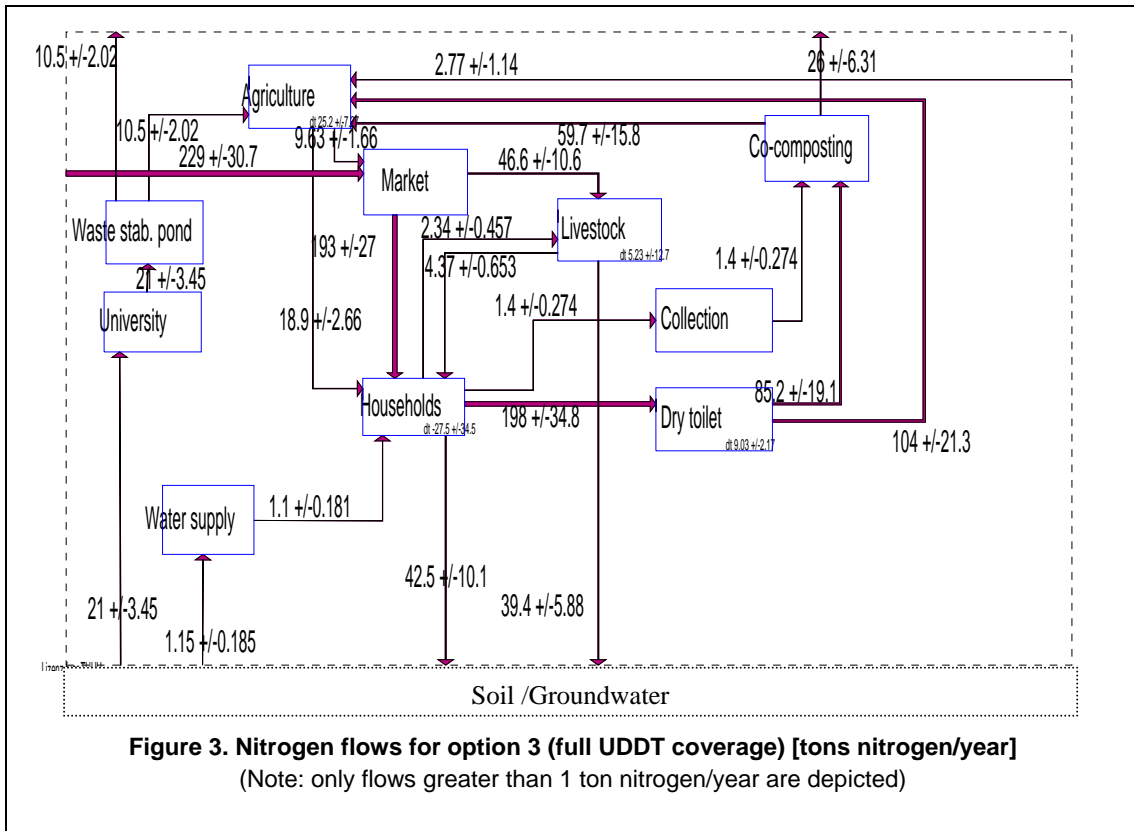

The analysis shows that even the implementation of UDDT and the subsequent use of urine and compost in only those households that currently practice open defecation (option 1), can replace about 65% of the current nitrogen fertiliser demand and 35% of the current phosphorus fertiliser demand within the system boundaries. Figure 4 and 5 illustrate a more detailed view of the nutrient recovery potential of the different scenarios. Due to the fact that urine contains relatively higher nitrogen loads than faeces, the nitrogen recovery potential in the liquid phase is greater than in the solid phase. Regarding phosphorus, however, compost produced out of dry faeces and organic waste can represent an even more valuable nutrient source.

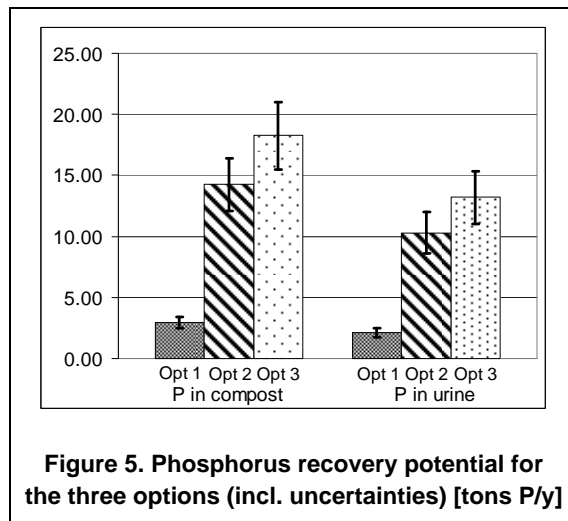
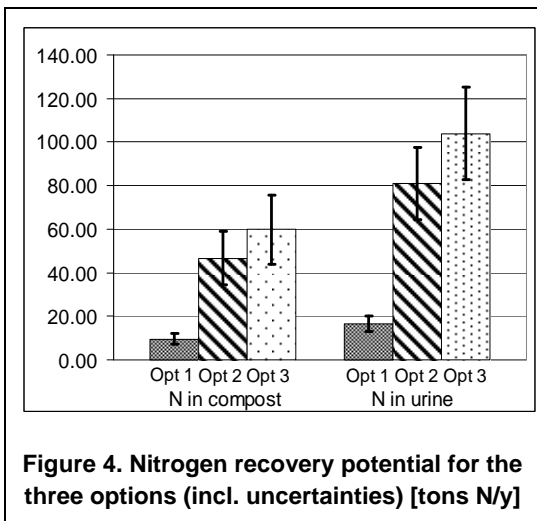

The analysis included factors accounting for nutrient losses due to volatilisation or leaching in the different processes. The results are based on an assumed nutrient content of excreta of $6.9 \pm 1.0 \text{gN}$ per person and day and $1.1 \pm 0.1 \text{gP}$ per person and day, which was calculated based on food proteins taken up in Ethiopia and the respective excretion rates (FAOSTAT, 2008; Jönsson et al., 2004). Furthermore, transfer coefficients for nutrients in excreta were used derived from Montangero and Belevi (2007).

The different recovery potentials of nitrogen and phosphorus are also illustrated in Figure 6. A parameter variation concerning the UDDT implementation rate shows that for full replacement of all nitrogen fertiliser the implementation of UDDT in about 20-35% (incl. uncertainties) of all households would be required (i.e. imports equal to zero). For phosphorus, however, about 40-50% of all households would need to separate their urine. With higher implementation rates, nutrients can be exported to neighbouring agricultural areas.

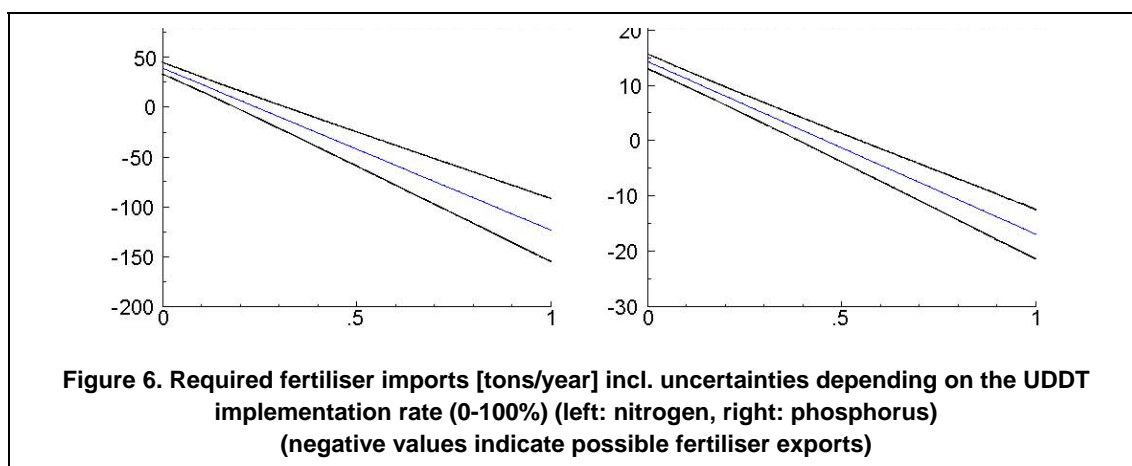

Another factor to consider for implementation is the resulting mass flows that need to be transported from the households to agriculture. Table 2 summarises the yearly transport loads for the different options. This means additional operational challenges, which need to be considered before the system can be implemented on a large scale. The transport can be organised by local enterprises, e.g. micro and small enterprises (MSEs), also in a labour-intensive way, thus contributing to employment and income generation. In addition, options for volume reduction of urine such as evaporation should be further investigated to reduce the total loads. In urban or peri-urban environments with relatively little agricultural activities by the households, it is important to identify other key actors like MSEs and farmers to allow for a proper operation of the system and creation of value chains.

Table 2. Transport requirements [1000 tons/year]		
	Liquid matter (urine)	Solid matter (compost)
Option 1	5.9 (± 0.8)	0.9 (± 0.2)
Option 2	28.9 (± 3.7)	4.2 (± 0.7)
Option 3	37.1 (± 4.7)	5.4 (± 0.9)

Conclusion and outlook

The MFA model for the water and wastewater system in Arba Minch highlights not only the current pollution due to uncontrolled disposal of wastes, but also helps identifying possibilities for a change towards more sustainable sanitation. Modelling the introduction of urine diverting toilets shows a greatly reduced discharge of eutrophying nutrients into the environment and a high potential for replacement of mineral fertiliser. For example, the implementation of urine-diverting toilets in about 25% of the households would be sufficient to replace the current nitrogen fertiliser demand of Arba Minch town. In future, other scenarios of resource-oriented sanitation technologies such as anaerobic digestion of blackwater will be included in the material flow analysis to support the planning process. In addition, first demonstration units are implemented in Arba Minch to overcome any possible barriers in terms of user acceptance. Promotion and testing is being done and the municipality together with the ROSA team develops strategies for sustained

implementation and operation of the system. These strategies also include micro and small enterprises as actors for the construction of the facilities, collection of urine, faeces and organic waste as well as post-processing before the final use in agriculture.

Acknowledgements

The author would like to extend special thanks to the ROSA team in Arba Minch. The work is carried out within the project ROSA (*Resource-Oriented Sanitation concepts for peri-urban areas in Africa*; Contract No. 037025-GOCE; duration: 1.10.2006 – 31.3.2010), a Specific Target REsearch Project (STREP) funded within the EU 6th Framework Programme, Sub-priority "Global Change and Ecosystems".

References

- AMU and ARB (2007) *Baseline Study Report of Arba Minch Town*. Report for the Project "Resource Oriented Sanitation Concepts for Peri-Urban Areas in Africa (ROSA)". Arba Minch University & Arba Minch Town Water Service.
- Baccini P. and Bader, H.-P. (1996) *Regionaler Stoffhaushalt*, Spektrum Akademischer Verlag, Heidelberg, Germany.
- Belevi H. (2002) Material flow analysis as a strategic planning tool for regional waste water and solid waste management. In: *Globale Zukunft: Kreislaufwirtschaftskonzepte im kommunalen Abwasser- und Faekalienmanagement*. München, Germany, 13-15 May.
- Brunner P. H. and Rechberger, H. (2004) *Practical Handbook of Material Flow Analysis* Advanced methods in resource and waste management series, Lewis Publishers, Boca Raton, Florida.
- Demilew A. (2008) *Ethiopia - Fertilizer price hits \$1,000/ton*.
http://nazret.com/blog/index.php?title=ethiopia_fertilizer_price_hits_1_000_ton&more=1&c=1&tb=1&pb=1.
- DHV Consultants (2002) *Environmental Support Project, Component 3. Arba Minch Water Supply and Sanitation*. Ministry of Water Resources, Ethiopia.
- Esatu E. (2008) Social and cultural standards of hygiene and comfort in new sanitation technologies; a case study of urine diversion dry toilets (UDDT) in Arba Minch Ethiopia. In: IWA Conference on Millenium Development Goals on Sanitation. 30.9.2008-01.10.2008. Amsterdam, The Netherlands, International Water Association.
- FAOSTAT (2008) *Food Balance Sheets for Ethiopia*. <http://faostat.fao.org/>. (accessed 10 July 2008).
- Forster D., Schertenleib R. and Belevi H. (2003). *Linking urban agriculture and environmental sanitation*. <http://www.sandec.ch/Publications/PublicationsHome.htm#UA>.
- Jönsson H., Richert Stintzing, A., Vinneras, B. and Salomon, E. (2004) *Guidelines on the Use of Urine and Faeces in Crop Production*. EcoSanRes Publications Series Report 2004-2. ISBN 91 88714 94 2.
- Kirchmann H. and Petterson, S. (1995) Human urine - Chemical composition and fertiliser use efficiency. In: *Fertilizer Research*. Kluwer Academic Publishers. vol 40, 149-154.
- Meinzinger F. and Oldenburg, M. (2008) Characteristics of Source-Separated Household Wastewater Flows - a Statistical Assessment. In: Proceedings International IWA Conference. pp. 274 - 280. Sanitation Challenge: New Sanitation Concepts and Models of Governance, 19-21 May, 2008, Wageningen, The Netherlands.
- Montangero A., Cau, L. N., Viet Anh, N. and Belevi, H. (2004) Selection of appropriate decentralised sanitation alternatives in Vietnam. In: *Proceedings of the Second International Symposium on Southeast Asian Water Environment*. Tokyo, Japan. S. Ohgaki et al. (eds.). pp. 373 - 380.
- Montangero A. and Belevi H. (2007). Assessing nutrient flows in septic tanks by eliciting expert judgement: A promising method in the context of developing countries. In: *Water Research*. Elsevier. vol 41, 1052-1064.
- Robinson W. I., Lieberg, A. T. and Trebbi, L. (2006) *FAO/WFP Crop and Food Supply Assessment Mission to Ethiopia*. FAO/WFP, Special Reports and Alerts (GIEWS).
<ftp://ftp.fao.org/docrep/fao/008/j7071e/j7071e00.pdf> (accessed 17 Jan. 2008).
- Thitiphon S., Thammarat, K. and Montangero, A. (2005) Material flux analysis for planning of domestic solid waste and wastewater management: A case study in Pak Kret Municipality. In: *Proceedings of 4th National Environmental Conference, Environmental Engineering Association of Thailand..* Chonburi, pp.439-447.
- WHO (2006) *WHO guidelines for the safe use of wastewater, excreta and greywater. Vol IV: Excreta and greywater use in agriculture*, World Health Organization.

Notes

1. It should be noted here that urine provides comparatively more nitrogen than phosphorus. Therefore, no application of excess phosphorus is expected through the fertilisation with urine.
-

Keywords

Material flow analysis, urine diversion, nutrient recovery, ecological sanitation.

Contact details

Dipl.-Ing. Franziska Meinzinger MAppIsc
Hamburg University of Technology (TUHH)
Institute of Wastewater Management and Water Protection
Eissendorfer Str. 42, 21071 Hamburg, Germany.
Tel: +49-(0)40-42878 2416
Fax: +49-(0)40-42878 2684
Email: f.meinzinger@tuhh.de
www: <http://www.tuhh.de/aww/>
