

## **ecosan demonstration project at the head-quarters of the gtz, Germany**

**C. Werner\***, **A. Panesar**, **S. Rüd** (all three gtz-ecosan)

\* ecosan program, Deutsche Gesellschaft für Technische Zusammenarbeit (GTZ) GmbH  
Dag-Hammarskjöld-Weg 1-5 , 65760 Eschborn, Germany  
e-mail: christine.werner@gtz.de  
Tel: ++49-6196-79-4221  
Fax: ++49-6196-79-7458

**Abstract:** As part of the recent renovation work at the main building of the Deutsche Gesellschaft für Technische Zusammenarbeit (GTZ) GmbH in Eschborn, Germany, a modern system for the separate collection and potential reuse of urine and brown water (faecal matter mixed with flushing water) was implemented. The direct aims of the project are to reduce water consumption, minimise the emission of nutrients and micro contaminants into the public sewer system and receiving water bodies, and enable the recovery of nutrients for agricultural use and water. The project also demonstrates on the feasibility and the advantages of the system and contributes to the global dissemination of the ecological sanitation concept.

As part of the project, GTZ, together with several universities and private companies will carry out an accompanying research and development programme, with the aim of developing different treatment technologies for urine and brown water and arrange of reuse practices, and to develop these to the point where they can enter the market. Crucial questions concerning user acceptance, environmental and health impact of urine reuse, economics and resource efficiency, and the appropriateness of the regulatory framework will also be studied. The project offers a unique opportunity to research institutions and private companies to carry out applied research on real-scale on concepts for closed-loop wastewater management.

**Keywords:** GTZ, ecosan, flow stream separation, decentralised treatment, office building

### **INTRODUCTION**

The Deutsche Gesellschaft für Technische Zusammenarbeit (GTZ) GmbH is an enterprise for international cooperation, working for sustainable development worldwide. On behalf of the German Ministry for Economic Cooperation and Development (BMZ), GTZ implements the ecological sanitation (ecosan) programme that develops and promotes ecosan concepts around the world.

The main building of the GTZ headquarters is located in Eschborn, near Frankfurt am Main, Germany. When it became clear that the GTZ main office building was to be renovated, the GTZ ecosan team initiated and promoted the implementation of an ecosan demonstration and research project as part of the renovation. The renovation work began in 2004, and finished in 2006, and a modern system for the separate collection and reuse of urine, and a treatment and reuse system for brown water (faecal matter mixed with toilet flushing water) is now being used by GTZ staff.

The main objectives of the project are to:

- Reduce the emission of pathogens, organics, nutrients, and micro pollutants, such as pharmaceutical residues and hormones to the public sewer system and receiving water bodies
- Protect water resources
- Recover nutrients for agricultural use
- Demonstrate the implementation of the ecosan concept in an urban context
- Contribute to the international dissemination of ecosan
- Research technical, operational, legal, social, economic and agricultural aspects of the system
- Develop ecosan technologies and operation for modern urban buildings.

The project is being implemented in two phases:

**Phase I:** The construction of the urine separation, collection and storage system as part of the renovation works, financed by GTZ and supported by the HMULV (Hessen State Ministry for Environment).

**Phase II:** The implementation of a urine treatment and reuse system, and of a brown water treatment and reuse system within a research project, which will be financed by the BMBF (German Federal Ministry for Education and Research) and the research partners.

## CONCEPT AND TECHNOLOGIES

The ecosan concept for the GTZ main building is summarised in Figure 1. The overall concept is to ensure a separate collection of urine, brown water and greywater within the building.

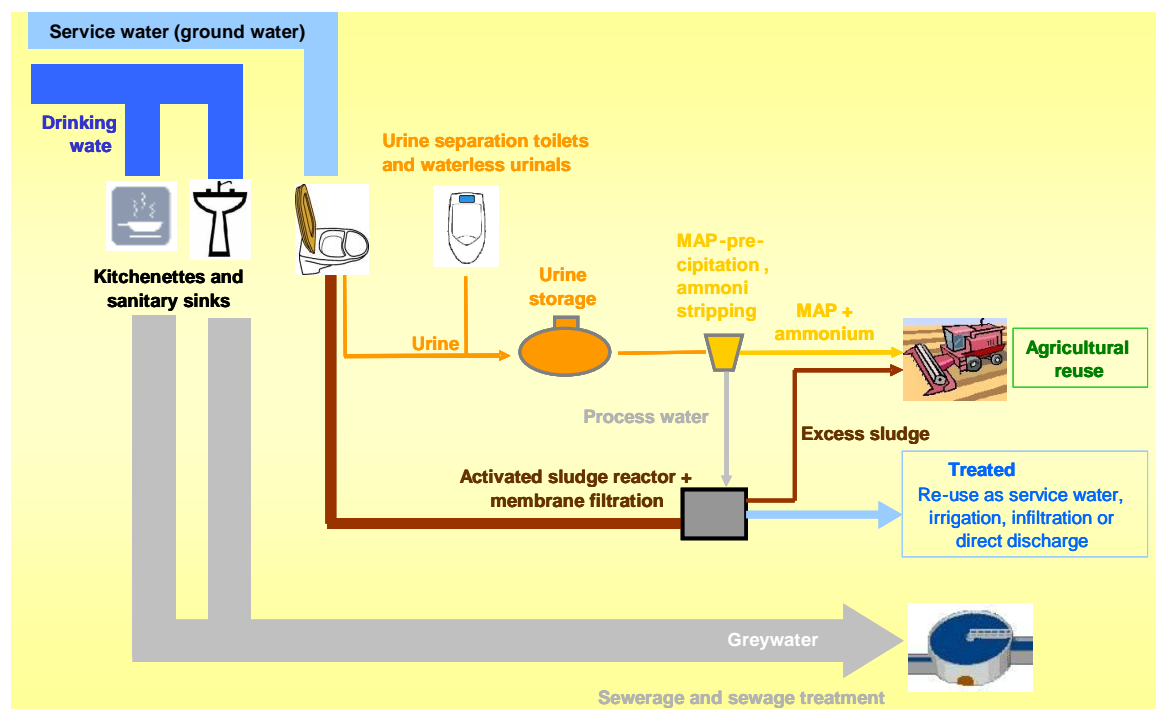

**Figure 1** Flowchart of the ecosan system implemented in the GTZ main building (source: GTZ)

The urine is stored in a tank before further treatment or possibly direct agricultural use. Modular treatment units will produce fertiliser and reclaimed water from the urine and brown water. As the service water for the GTZ office currently comes from a local well, used to lower the high local groundwater level for the underground car-park, the grey water is neither treated, nor reused, and is evacuated to the sewer system so that its treatment still has to be assured by the central-wastewater treatment plant located in Frankfurt-Niederrad. As shown in Figure 2, the ecosan system is implemented in the central part of the building, which accommodates about 300 employees, the conference rooms and the restaurant. The total number of persons using the system regularly is estimated to be around 400 people per working day.

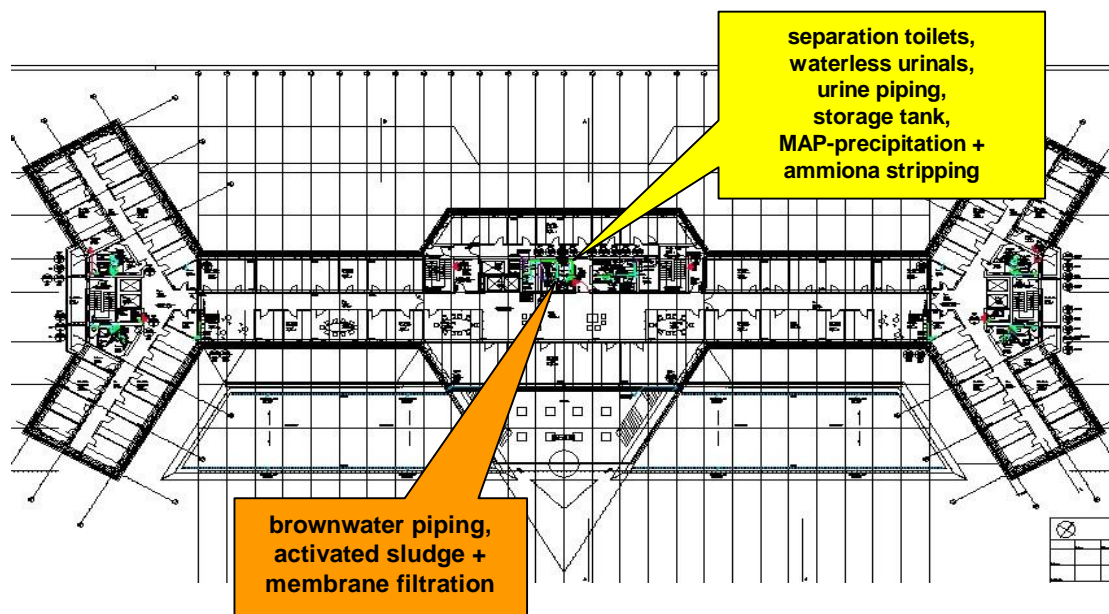
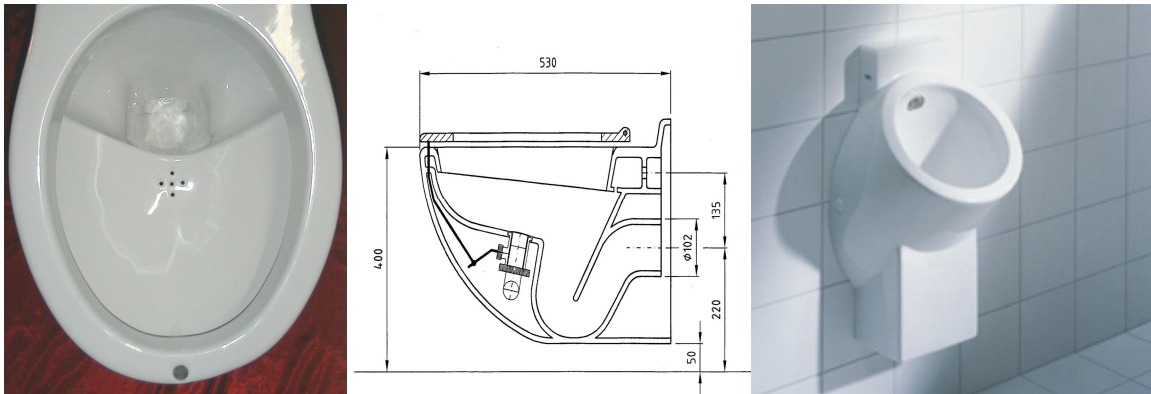

**Figure 2** Plan of the GTZ headquarters, showing the location of the ecosan systems in the sanitary blocks in the central part of the building (source: GTZ)

### Urine separation system

The urine separation system consists of:

- 56 water flushed urine separation toilets for the waterless collection of urine (model Roediger). The toilets have two different bowls for urine and brown water respectively. The urine is collected undiluted by means of a valve located under the toilet seat, triggered when the user sits down. This toilet consumes about 1-2 l for the urine flush and 4 to 6 l for the solids flush (Figure 3).
- 25 waterless urinals made of sanitary porcelain and equipped with a patented membrane smell stop system (type Keramag Centaurus) (Figure 3).
- A separate piping system for urine collection consisting of pipes of three different diameters (50, 80 and 100 mm) made of cast iron with an enamel coating (Figure 4).
- A total volume of 10 m<sup>3</sup> for urine collection and storage. Tanks are made of Polyethylene PE, are grouped in 4 units of 2.5 m<sup>3</sup> each in the basement of the building, and are equipped with sampling and level measure devices (Figure 4).



**Figure 3** Urine separation toilet (source: Roediger) and waterless urinal (source: Keramik)

### Urine treatment

The urine treatment will be implemented within the planned research project. Two treatment options have been chosen to be implemented on a real scale:

- Treatment by prolonged storage for direct application of urine to fields
- Precipitation of phosphorous and nitrogen from urine by the addition of magnesium oxide for the production of Magnesium-Ammonium-Phosphate (MAP-precipitation), combined with the stripping and adsorption of excess ammonium.

Further treatment options will also be tested on a laboratory-scale and for demonstration purpose, including nutrient adsorption on zeolites or thermal urine concentration.



**Figure 4** Pipes of cast iron with enamel coating (left), urine tanks (middle), and docking station for tank trucks (right) (source: GTZ)

### Brown water treatment

A treatment system for brown water from toilet flushing will be implemented as well in the foreseen research project. An appropriate brown water treatment will be assured by an aerobic activated sludge reactor followed by a membrane filtration.

## WATER SAVING

Water saving was already considered important in the GTZ buildings even before the recent renovation. All buildings are equipped with water efficient fittings. Two buildings,

including the main building, are equipped with a separate service water system for toilet flushing, hand washing and cleaning, using the groundwater that is pumped to ensure that the underground car-park remains dry. The groundwater is used as service water in preference to expensive municipal drinking water. This practice however ensured that grey water recycling was not a cost efficient option for the GTZ building and has therefore not been implemented. The use of the urine separating low flush toilets and the waterless urinals will reduce the water consumption for toilet flushing by about 900 m<sup>3</sup> per year, compared to conventional toilets, and by another 2000 m<sup>3</sup> per year, if the treated brown water is used for toilet flushing.

## **ENERGY EFFICIENCY**

The GTZ main building was constructed in 1976 and the resulting environmental performance was far below today's standards. With the complete renovation of the facade and the use of energy efficient heating systems and boilers the energy consumption will be reduced by approximately 50%. The new ground design and a green roof (about 50% of the total surface) enhance a positive microclimate and reduce rainwater run-off.

## **TYPE OF REUSE**

The reuse of treated urine and brown water will begin as part of the research project. The stored urine and the mineral nutrients extracted from urine will be used to fertilise agricultural research plots. The use of urine on research plots is currently the only legal reuse option for urine in agriculture, as German fertiliser law does not yet recognise urine as a fertiliser and exceptional permits are therefore required for its use. The treated brown water is hygienically safe and good for reuse as service water, for green irrigation or groundwater recharge. It is also planned to reuse the sludge from the brown water treatment in agriculture.

## **RESEARCH**

Several universities, private companies and GTZ will jointly carry out a research and development project related to the ecosan system in the GTZ headquarter. The focus of the research will be the development of treatment technologies and reuse practices, as well as aspects of user acceptance, environmental and health issues (particularly with regard to micro pollutants), legal and economic aspects, resource efficiency, and the applicability of the system in industrialised, emerging and developing countries.

## **DEMONSTRATION**

The GTZ headquarters in Eschborn are visited daily by decision makers from all over the world. This makes the GTZ-main building the ideal location for the demonstration of innovative ecosan concepts. A special demonstration room will allow visitors to learn about the system and the concept behind it.

GTZ's project is complemented by the ecosan project in the headquarters of KfW Bankengruppe in Frankfurt, where low-flush vacuum toilets, vacuum sewerage, and grey

water recycling has been implemented. With these projects, two major actors in German development cooperation are clearly demonstrating their commitment to innovative ecological sanitation concepts within their own buildings.

## COSTS

A detailed cost benefit analysis of the investment and operation costs will be carried out as part of the research component of the project. A first cost estimate is given in the tables below. However, as some of the technical elements used for this ecosan system are only prototypes (e.g. the urine and brown water treatment), or are currently only being manufactured in small numbers (e.g. the urine separation flush toilets), or have had to be specifically manufactured to fit into the existing building (e.g. urine tanks), or have been designed with an extra factor of safety by the construction company due to lack of experience with source separation technology (e.g. the urine pipe with enamel coating), the given installation costs obviously can not be directly applied for larger scale ecosan systems. The specific cost factors, such as the unit cost for the urine-diversion toilet, or the cost for collection tanks and pumps, may be significantly reduced when implemented in larger scale and / or in new buildings.

Despite these difficulties, Table 1 below shows three different scenarios that have been developed, to try and make some first cost comparisons for (1) a conventional system, (2) the GTZ building prototype, and (3) an ecosan large scale application. The large scale scenario is based on two assumptions: Firstly, a reduction of the unit costs due to economies of scale and, secondly, a completion of the prototype urine and brown water treatment and reuse system, which would consequently render a centralised sewerage system superfluous.

**Table 1:** Scenarios for cost comparison

<b>Scenario 1: Conventional system</b>	<b>Scenario 2: GTZ building prototype</b>	<b>Scenario 3: ecosan large-scale</b>
<ul style="list-style-type: none"> <li>▪ public water supply for all uses</li> </ul>	<ul style="list-style-type: none"> <li>▪ use of public water supply for kitchenette and handwashing</li> <li>▪ use of well water for toilet flushing</li> </ul>	<ul style="list-style-type: none"> <li>▪ use of public water supply for kitchenette and handwashing</li> <li>▪ use of recycled greywater for toilet flushing</li> </ul>
<ul style="list-style-type: none"> <li>▪ no water saving devices</li> </ul>	<ul style="list-style-type: none"> <li>▪ waterless urinals</li> <li>▪ watersaving separation toilets</li> </ul>	<ul style="list-style-type: none"> <li>▪ waterless urinals</li> <li>▪ watersaving separation toilets</li> </ul>
<ul style="list-style-type: none"> <li>▪ no reuse</li> </ul>	<ul style="list-style-type: none"> <li>▪ reuse, infiltration or discharge of treated brownwater</li> <li>▪ reuse of urine</li> </ul>	<ul style="list-style-type: none"> <li>▪ reuse, infiltration or discharge of treated grey- and brownwater</li> <li>▪ reuse of urine</li> </ul>
<ul style="list-style-type: none"> <li>▪ discharge of wastewater in public sewer system</li> </ul>	<ul style="list-style-type: none"> <li>▪ discharge of greywater in public sewer</li> </ul>	<ul style="list-style-type: none"> <li>▪ no sewer connection</li> </ul>

Table 2 gives an overview of the cost estimate for the implementation of the sanitary and treatment infrastructure for the GTZ-building prototype compared to a conventional

system. As prototype costs are usually higher than costs of systems which are produced in large numbers or at large scale, the table also gives an estimate of the costs of the ecosan system if it would be implemented at large scale and not as a prototype only. Especially with regard to the unit costs of the urine diversion toilets, which are presently about six times higher than unit costs of conventional toilets, or optimisation of the modular treatment units, it is estimated, that the overall investment cost could be significantly reduced.

The estimated investment costs for the urine and brown water separation system, including separation toilets, waterless urinals, separate pipe system for urine and brown water, storage tanks, auxiliary equipment and the demonstration rooms are 219,000 €

Estimated additional costs of the urine and brown water separation system compared to conventional sanitary facilities (conventional toilets and urinals, no separate urine pipe system, storage tank, etc.) are 159,000 Euros (Table 2). The cost estimations for urine treatment, brown water treatment, reuse and research activities are not yet available.

Compared to conventional water flush toilets and urinals, the water consumption will be reduced by approximately 900 m<sup>3</sup> annually, resulting in cost savings for water supply and sewerage fees. Financial benefits also arise from produced fertilisers. The recovered urine and brown water is sufficient to fertilize up to 60 ha of agricultural land. However those cost savings have to be compared to the operation costs of the on-site treatment and the reuse (Table 2).

**Table 2:** Cost estimation for the sanitary and treatment infrastructure for the GTZ-building prototype compared to a conventional system and to an ecosan large scale application

	Conventional system (€)	GTZ building prototype (€)	ecosan large-scale (€)
<b>Sanitary infrastructure</b>			
Conventional urinals	10.000	-	-
Waterless urinals	-	10.000	10.000
Conventional toilets	15.000	-	-
UD toilets	-	76.000	25.000
Blackwater pipe system	35.000	-	-
Urine pipe system	-	33.000	20.000
Brownwater pipe system	-	35.000	20.000
Greywater pipe system	-	20.000	20.000
Urine collection tank + pumps	-	45.000	20.000
<b>Subtotal Sanitary Infrastructure</b>	<b>60.000</b>	<b>219.000</b>	<b>115.000</b>
<b>Treatment infrastructure</b>			
Urine treatment	-	45.000	20.000
Brownwater treatment	-	60.000	30.000
Greywater treatment	-	-	30.000
Sewerage network (proportionately)*	450.000	450.000	-
Sewage treatment (proportionately)*	45.000	23.000	-
<b>Subtotal Treatment</b>	<b>495.000</b>	<b>578.000</b>	<b>80.000</b>
<b>Total</b>	<b>555.000</b>	<b>797.000</b>	<b>195.000</b>
<b>Difference</b> (compared to conventional scenario)	<b>+ 0</b>	<b>+ 242.000</b>	<b>-360.000</b>

\* Estimated with European average costs

**Table 3:** First estimate of the operation costs of the ecosan-system in the GTZ-building

	<b>Conventional system (€/year)</b>	<b>GTZ building prototype (€/year)</b>	<b>ecosan large-scale (€/year)</b>
<b>Water supply*</b>			
urinals	1100	0	0
toilets	4800	0	0
kitchenettes, sanitary sinks	1600	1600	1600
<b>Wastewater fees*</b>	7500	1600	0
<b>Onsite treatment + transport</b>			
yellowwater	0	5000	2500
brownwater	0	7000	3500
greywater	0	0	3000
<b>Income from products</b>			
fertilizer value of urine and sludge	0	not considered	not considered
<b>Total</b>	<b>15000</b>	<b>15200</b>	<b>10600</b>
<b>Difference</b>			
compared to conventional scenario	<b>0</b>	<b>200</b>	<b>-4400</b>

\* Costs for water supply and waste water are calculated with 2 EUR/m<sup>3</sup> each

Following these first estimates the maximum cost savings could be achieved, if all the wastewater fractions would be treated on-site and reused, in a building that would not require a sewer connection.

## CONCLUSION

GTZ has taken the opportunity presented by the renovation of its main building to implement an ecosan system for the treatment and reuse of urine and brown water. The reuse component of the project will be carried out in a joint research and development programme together with several universities and private companies.

The goal will be to develop various treatment technologies for urine and brown water treatment and reuse practices, and to develop these up to the point of market readiness. Crucial questions such as user acceptance, environmental and health impact of urine reuse, economics and resource efficiency, as well as the regulatory framework will also be studied.

The project offers a unique chance for research institutions and private companies for applied research on a real-scale on concepts for closed-loop wastewater management and will be a good example, together with the existing KfW headquarters sanitation system in Frankfurt, of ecosan approach applied to office buildings.